

---

# Engineering Mechanics

---

**Text Book:** *Engineering Mechanics–Statics and Dynamics*, I. H. Shames, Fourth Edition, Prentice Hall of India.

**Mohammed Ameen, Ph.D**  
Professor of Civil Engineering



*National Institute of Technology Calicut*

# Introduction

- Mechanics is the branch of engineering dealing with bodies and their dynamical behaviour
- Oldest of physical sciences (writings of Archimedes covering buoyancy and lever were recorded as early as 200 B.C)
- Newtonian mechanics – Isaac Newton (1642–1727)
- Einstein’s limitations (1905)
  - valid when the speed of a body approaches that of light (300,000 km/s) — “relativistic mechanics”;
  - Small scale phenomena involving subatomic particles — “quantum mechanics”.
- Such speeds are encountered in the large-scale phenomena of astronomical bodies and small-scale phenomena like subatomic particles.
- Yet, in the great bulk of engineering applications, Newtonian mechanics is valid.



*Mechanics* has several branches:

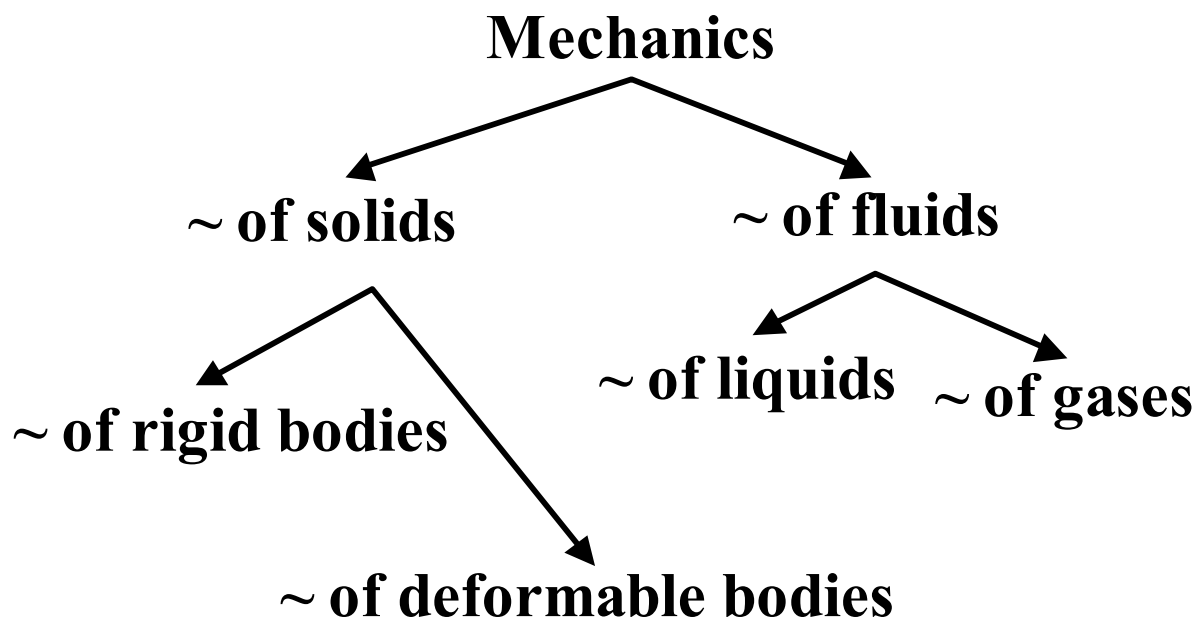

Another classification is based on whether the body is at rest (or moving with a uniform velocity) or in motion. Thus,

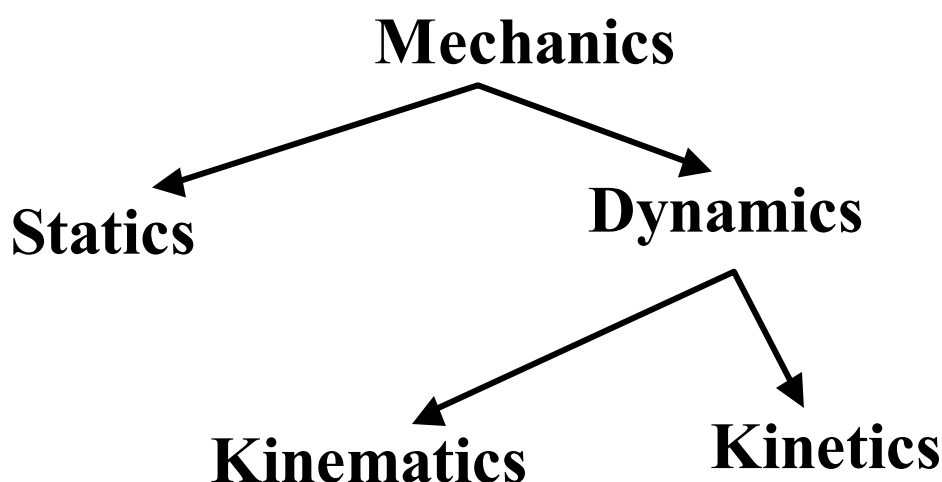

# Basic Dimensions and Units of Mechanics

- *Dimensions*: are the abstractions used to describe the characteristics of a body that interest us.
- Dimensions which are independent of all other dimensions “*Basic or Primary Dimensions*”
- Dimensions which are developed in terms of the basic dimensions “*Secondary Dimensions*”
- **Length**: A concept for describing size quantitatively—the *metre* bar kept at Sévres, France acts as the standard.
- Other aspects of size such as area and volume can be represented in terms of the standard by employing principles of geometry.
- **Time**: used to describe the ordering of the flow of events
- The rotation of earth gives rise to a standard to measure time—the day, which is further divided into hour, minute, second and so on.



- **Mass:** a property of matter that can be determined based on the amount of gravitational attraction of the body under consideration. The unit in SI system is *kilogram*.

- Can be determined from the actions of a body

- If both *A* and *B* produce the same amount of extension when attached to identical springs

- If we pull each body by the same amount and release, and if both move in an identical manner

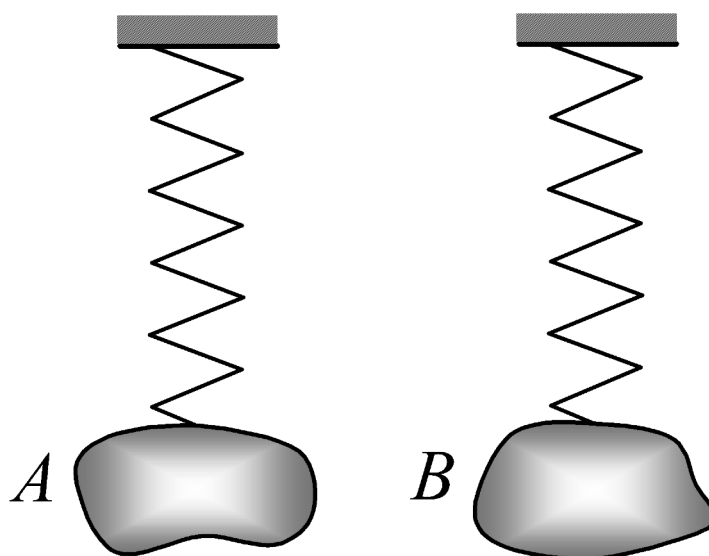

**Table 1** Basic dimensions and their units

Basic Dimension	Symbol	Units	
		SI	cgs
Mass	$M$	Kilogram, kg	Gram, g
Length	$L$	Metre, m	Centimetre, cm
Time	$T$	Second, s	Second, s

## Secondary Dimensional Quantities

For example:

$$\text{Velocity} \equiv [L][T]^{-1}$$

$$\text{Acceleration} \equiv [L][T]^{-2}$$

$$\text{Force} \equiv \text{mass} \times \text{acceleration}$$

$$\equiv [M][L][T]^{-2}$$

$$\text{Density} \equiv [M][L]^{-3}$$

Note: There is another system of basic dimensions consisting of  $[F]$ ,  $[L]$  and  $[T]$ , instead of  $[M]$ ,  $[L]$  and  $[T]$ .



- *Law of Dimensional Homogeneity*: Basic equations representing physical phenomenon should be valid for all systems of units
- For this to occur, every term in an equation should have the same dimensional representation.
- For example:  $x = u t + \frac{1}{2} a t^2$  has the same dimensional representation of [L] for each of the three terms.

### **Usual confusion between force and mass**

- All confusions regarding the units of mass and force can be easily avoided by sticking to Newton second law of motion:

$$F = m a.$$

- The SI unit of mass is kg (kilogram) and that of force is N (Newton).
- Hence, 1 N is that force which causes 1 kg of mass to accelerate with  $1 \text{ m/s}^2$ .
- In terms of kilogram force ( $\text{kg}_f$ ),  $1 \text{ kg}_f = 9.81 \text{ N}$ , and is the weight of 1 kilogram mass at the earth's surface, where the acceleration due to gravity is  $9.81 \text{ m/s}^2$ .



# Idealisations of Mechanics

- Often, it is necessary to replace the actual physical actions and the participating bodies with hypothetical and simplified substitutions so as to arrive at solutions that are easier and yet are close to the physical reality.
- Considerable amount of imaginations, ingenuity and insight are needed to arrive at such idealisations.
- The fundamental idealisations of mechanics are the following:
  - (i) *Continuum*: Bodies are assumed to be made up of a hypothetical continuous distribution of matter, instead of the actual picture consisting of a conglomeration of discrete, tiny particles such as molecules, atoms, electrons, etc. (in contrast to the “*corpuscular theory*” which takes into account the atomic/subatomic structure of matter).





(ii) *Rigid body*: When the deformation of the body is not of interest, we are justified to make use of the rigid body idealisation in which the continuum is assumed not to undergo any deformation whatsoever.

For example, in the calculation of the forces transmitted to the supports by a beam, the considerations of the deflection of beam is unimportant.

The error that is caused by the rigid body assumption in this instance is negligible.

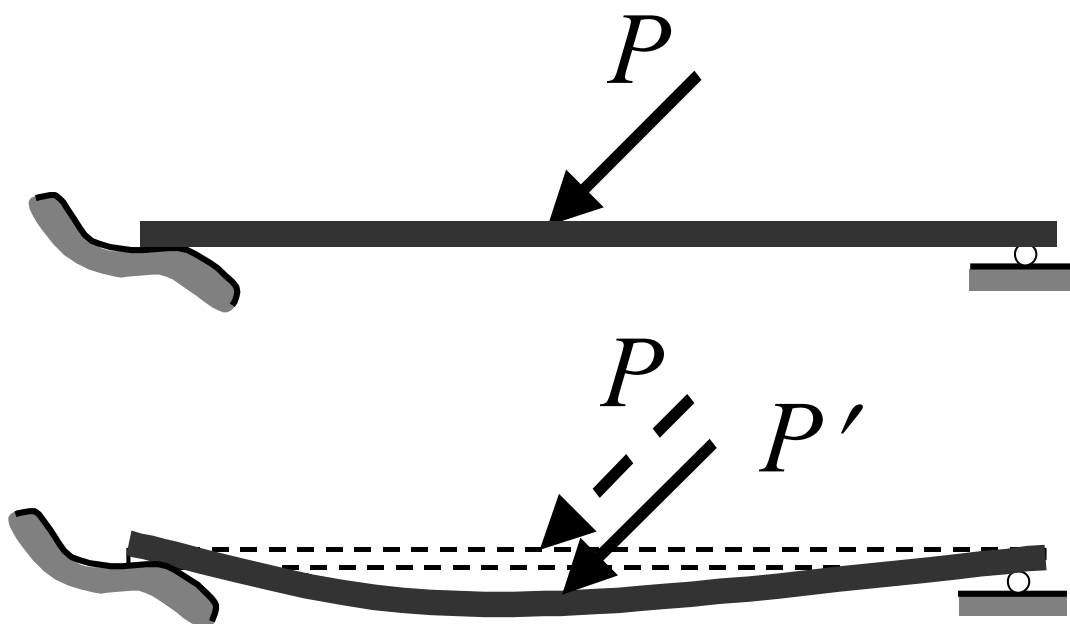

**Figure** Rigid body and deformable body

(iii) *Point force*: A finite force exerted on one body by another is always associated with a finite area of contact between the bodies.

- A point force is that idealisation in which we assume that a force is being applied through a single point (of area zero).

(iv) *Particle*: An object that has a mass but no size is called a particle.

- This is useful in dealing with the translatory motion of rigid bodies that could have the size of a car or even a planet.
- This assumption ceases to be valid when rotation of the rigid body is also involved.
- Many other simplifications pervade mechanics.



# Vector and Scalar Quantities

Many physical quantities could be described by means of their magnitude alone.

For example, the temperature at a point in a body or the mass of a particle.

Such quantities are called *scalars*.

On the other hand, there are certain quantities of interest, which need in addition to the magnitude the specification of a direction.

*Vectors*: have magnitude and direction, and add according to the parallelogram law

For example, the velocity of a car is a vector quantity as its description is complete with the specification of both the speed of the vehicle and its direction of motion.

Other examples are the force, the displacement of a point etc. (We shall see more about vectors later).

However, finite rotations are not vectors as they do not add as per the parallelogram law!



# Equality and equivalence of vectors

- Two vectors are equal if they have the same magnitudes (including the units) and direction
- Two vectors are said to be *equivalent* in a certain capacity if each produces the same effect in that capacity

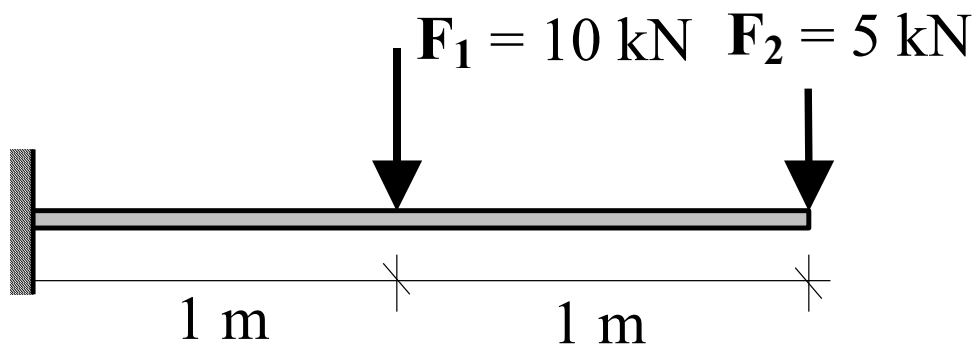

- the forces  $F_1$  and  $F_2$  in Fig. are not equal (as their magnitudes are different although the directions are the same), they are equivalent in terms of producing moments about the fixed end of the beam.

# Equivalent Vectors

- (i) *Free vectors*: vectors that can be positioned anywhere in space keeping their magnitude and directions intact.
- (ii) *Transmissible vectors*: are vectors that can be moved along their lines of action without change of magnitude and direction. For example, while towing a box, we may apply the force anywhere along a rope  $AB$  or push at  $C$ .

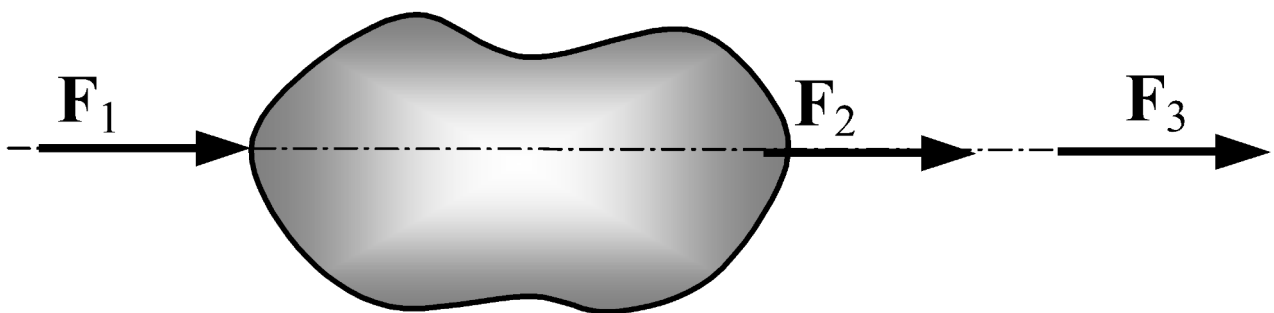

(iii) *Bound vectors*: are those which are applied to a fixed point; they can neither be moved parallel in space nor along the same line.

- As an example, if we are interested in the deformation of an elastic body due to a point force, the point of application of the force does matter (see Fig.).

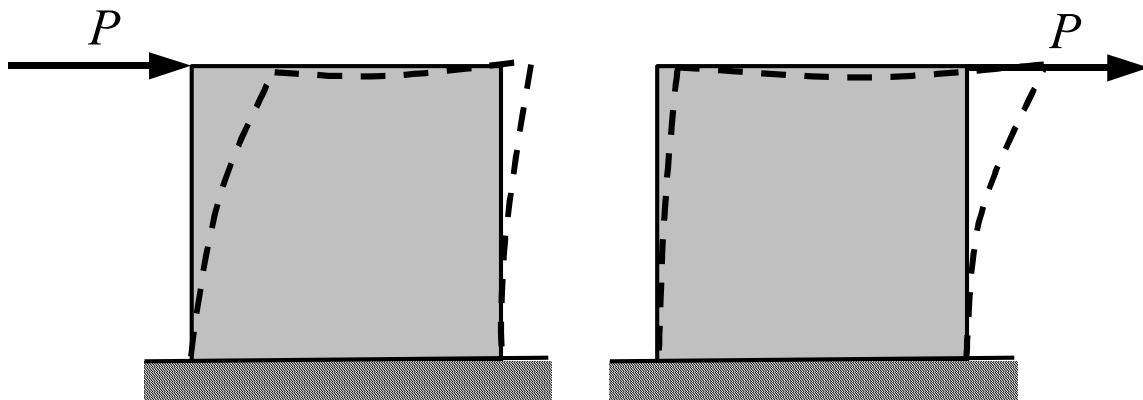

# Laws of Mechanics

The fundamental laws of mechanics are:

- (i) Newton's first and second laws of motion
- (ii) Newton's third law
- (iii) The gravitational law of attraction
- (iv) The parallelogram law

*Newton's first law:* Every particle continues in a state of rest or uniform motion in a straight line unless it is compelled to change that state by forces imposed on it.

*Newton's second law:* The change of motion is proportional to the natural force impressed and is made in a direction of the straight line in which the force is impressed.



- It is essential to consider a frame of reference while discussing the above two laws.
- It has been experimentally observed that the first and second laws of Newton are highly accurate with respect to the fixed stars as a reference.
- It is sufficient to consider any reference that moves uniformly and without rotation relative to the fixed stars as a reference with equal accuracy.
- All such references are called inertial references.
- The earth's surface is usually employed as a reference in most of the engineering works though it is not, strictly speaking, an inertial one (since it rotates).
- The error incurred in this is very small except when one deals with the motion of a guided missile or a spacecraft.





- *Equilibrium* is defined as that state of a body in which all its constituent particles are at rest or moving uniformly along a straight line relative to an inertial frame of reference.
- The converse of N's first law, then, stipulates that there must be no force acting on the body.
- Statics: The study of bodies in equilibrium Einstein set the limitations for the validity of Newton's law.
- However, these limitations are applicable only when the speeds approach that of light.
- *Newton's third law*: To every action there is always an equal reaction, or the mutual actions of two bodies upon each other are always equal and directed to contrary points.



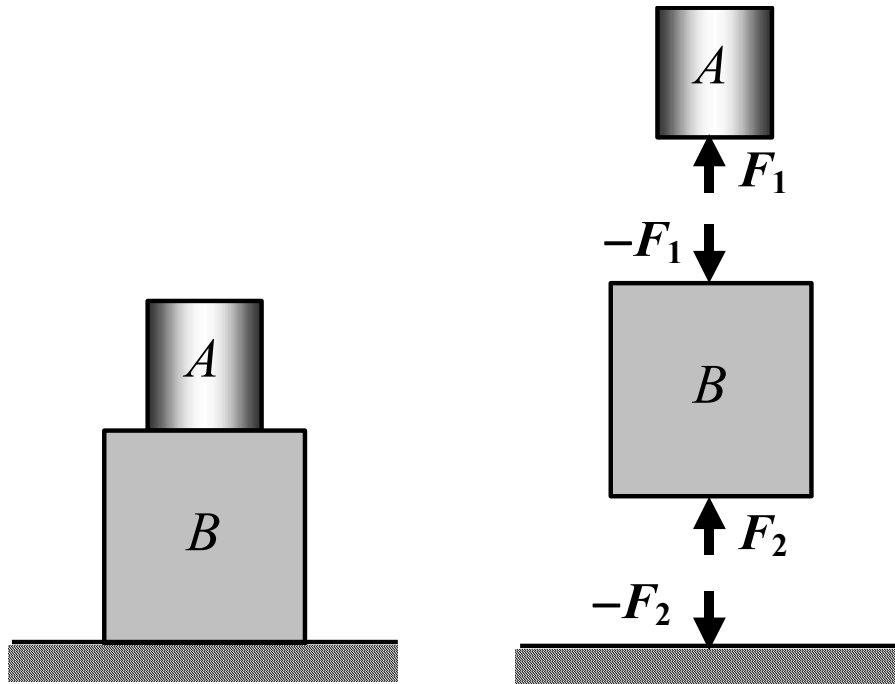

**Figure:** The action and reaction between two bodies in contact

- *Law of gravitational attraction:* Two particles will be attracted to each other along their connecting line with a force whose magnitude is directly proportional to the distance squared between the particles.

That is,

$$F = G \frac{m_1 m_2}{r^2}$$

where  $G$  is called the *universal gravitational constant*.



Parallelogram Law: Stevinus (1548-1620) showed that forces could be combined by representing them by the sides of a parallelogram; the diagonal then represents the sum.

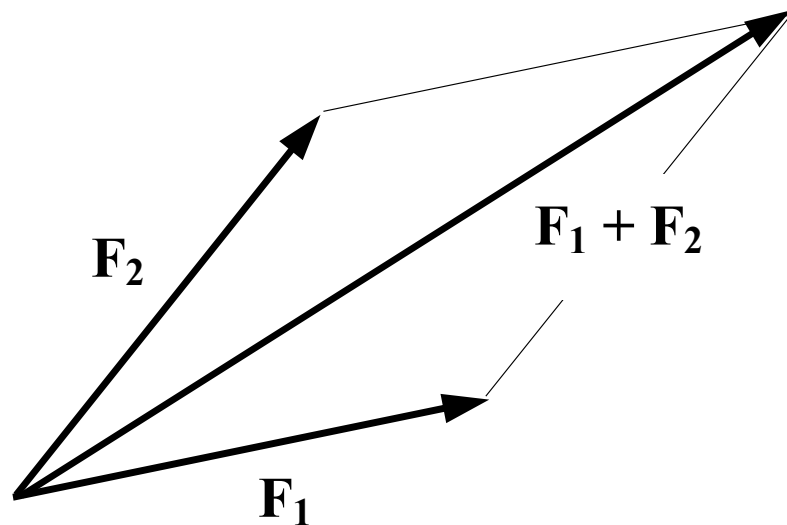

All vectors combine this way.

NOTE: Answer the questions on p22 of “Shames”



# Elements of Vector Algebra

- As we have seen before, a vector quantity needs the specification of direction in addition to its magnitude for its complete description.
- A directed line segment is often used to denote a vector quantity.

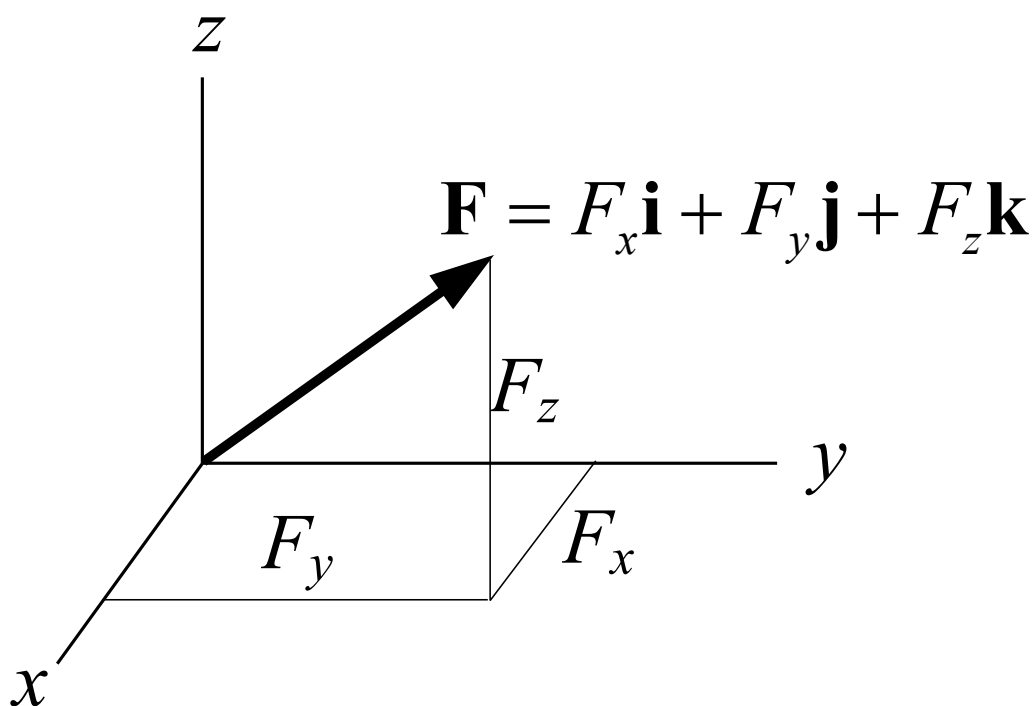

- For example, a point-force acting on a body at a point can be described using a vector  $\mathbf{F}$ .



- With respect to a coordinate system, such a vector could have components  $F_x$ ,  $F_y$  and  $F_z$ , along the  $x$ ,  $y$  and  $z$  directions respectively.
- Indicating the unit vectors along the axes by  $\mathbf{i}$ ,  $\mathbf{j}$  and  $\mathbf{k}$ , we can write the force vector as

$$\mathbf{F} = F_x \mathbf{i} + F_y \mathbf{j} + F_z \mathbf{k}$$

- We can also write this as

$$\mathbf{F} = \{F\} = \begin{Bmatrix} F_x \\ F_y \\ F_z \end{Bmatrix}$$

- Hence, a column matrix is often called a vector, too.



- In print, a boldface letter (e.g. **F**) indicates a vector.
- In writing we could use one of the following symbols to indicate vectors:

$$\vec{F}, \bar{F}, \tilde{F}, F$$

- The vector quantities add as per the *parallelogram law of vector addition*

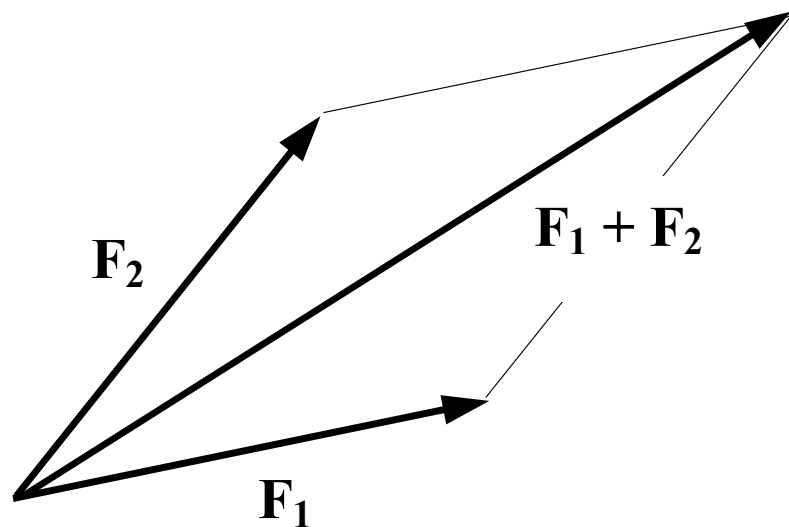

- All quantities that have magnitude and direction and that add according to the parallelogram law are called *vector quantities*
- Infinitesimal rotation is a vector; finite rotation is not.



## Magnitude & multiplication of a vector by a scalar

Magnitude of  $\mathbf{A} = A = |\mathbf{A}|$

$m\mathbf{A}$  is a vector of magnitude  $mA$  and direction that of  $\mathbf{A}$  (if  $m$  is +ve; else opposite)

## Addition and subtraction of vectors

Based on parallelogram law

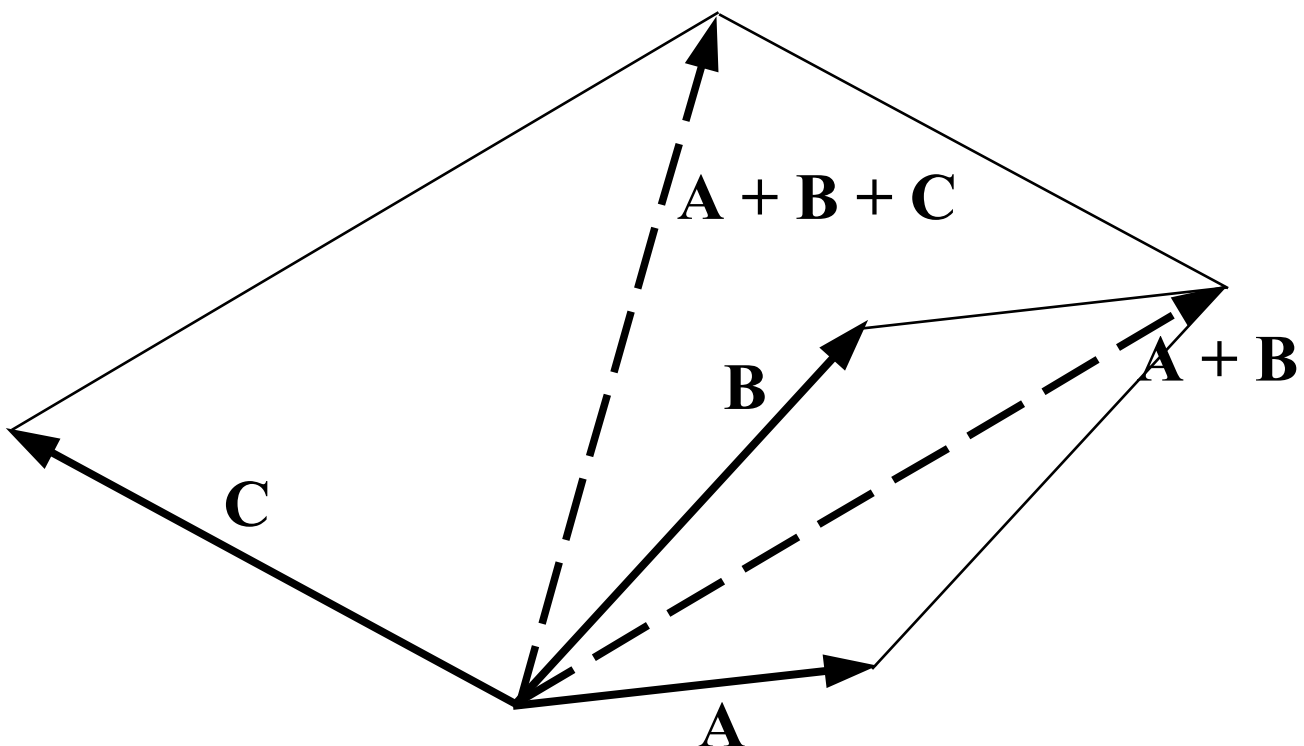

Also

$$\mathbf{A} + \mathbf{B} + \mathbf{C} = (\mathbf{A} + \mathbf{B}) + \mathbf{C} = \mathbf{A} + (\mathbf{B} + \mathbf{C})$$

Sine Rule:  $\frac{a}{\sin A} = \frac{b}{\sin B} = \frac{c}{\sin C}$

Cosine Rule:

$$c^2 = a^2 + b^2 - 2ab \cos C$$

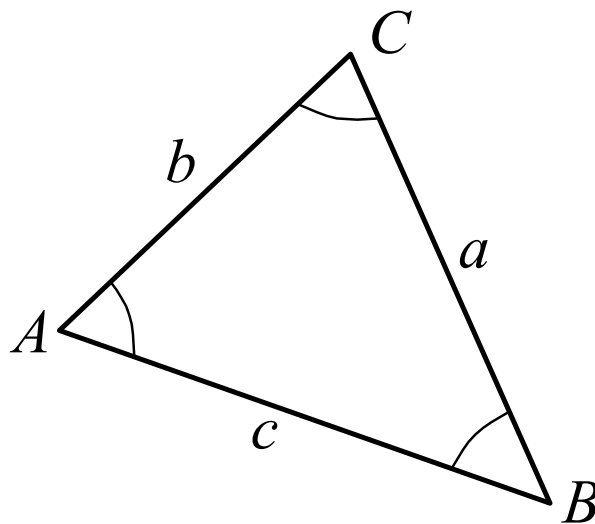

Subtraction:  $\mathbf{A - B = A + (-B)}$

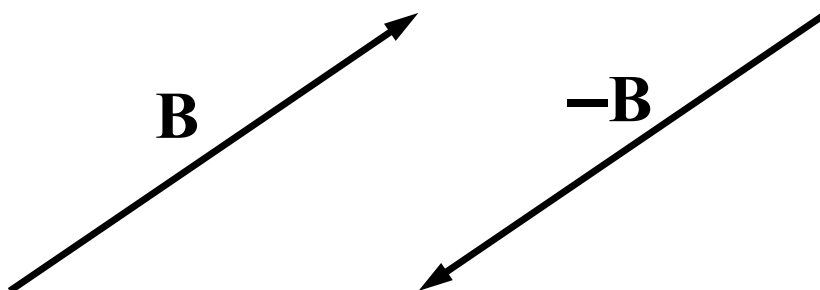



## Resolution of vectors: Scalar components

Given two directions, we can resolve a vector  $\mathbf{A}$  into components  $\mathbf{A}_1$  and  $\mathbf{A}_2$  along the two such that

$$\mathbf{A} = \mathbf{A}_1 + \mathbf{A}_2$$

We could resolve into two components in the same plane, or three non-coplanar components.

Resolving a vector along orthogonal directions is convenient very often

Unit vectors: A vector of unit magnitude and a specified direction

A given vector  $\mathbf{F}$  can be written as

$$\mathbf{F} = F \mathbf{f}$$

where  $\mathbf{f}$  is a unit vector along  $\mathbf{F}$ ;

Or

$$\mathbf{f} = \frac{\mathbf{F}}{|\mathbf{F}|}$$



Unit vectors along the coordinate directions—**i**, **j** and **k**—are very useful

$$\text{Thus } \mathbf{F} = F_x \mathbf{i} + F_y \mathbf{j} + F_z \mathbf{k}$$

The magnitude of **F** is given by

$$|\mathbf{F}| = \sqrt{F_x^2 + F_y^2 + F_z^2}$$

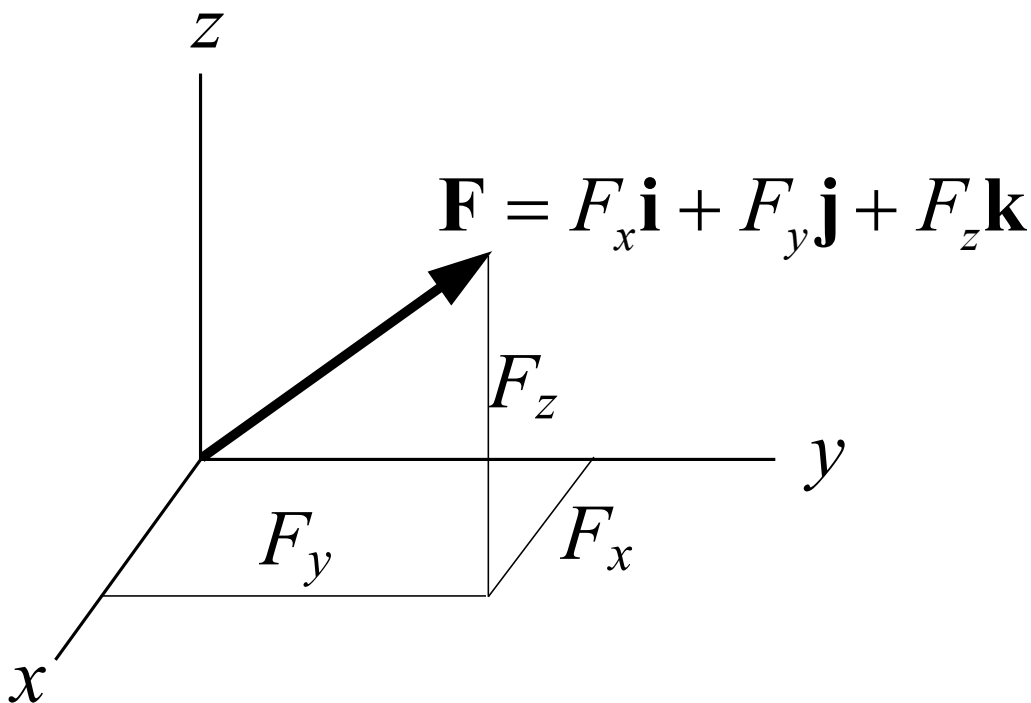

The direction cosines of the line of action of **F** are

$$l = \frac{F_x}{F}; \quad m = \frac{F_y}{F}; \quad n = \frac{F_z}{F};$$



## Useful Ways of Representing Vectors

The displacement vector from A to B is

$$\mathbf{\rho}_{AB} = (x_B - x_A)\mathbf{i} + (y_B - y_A)\mathbf{j} + (z_B - z_A)\mathbf{k}$$

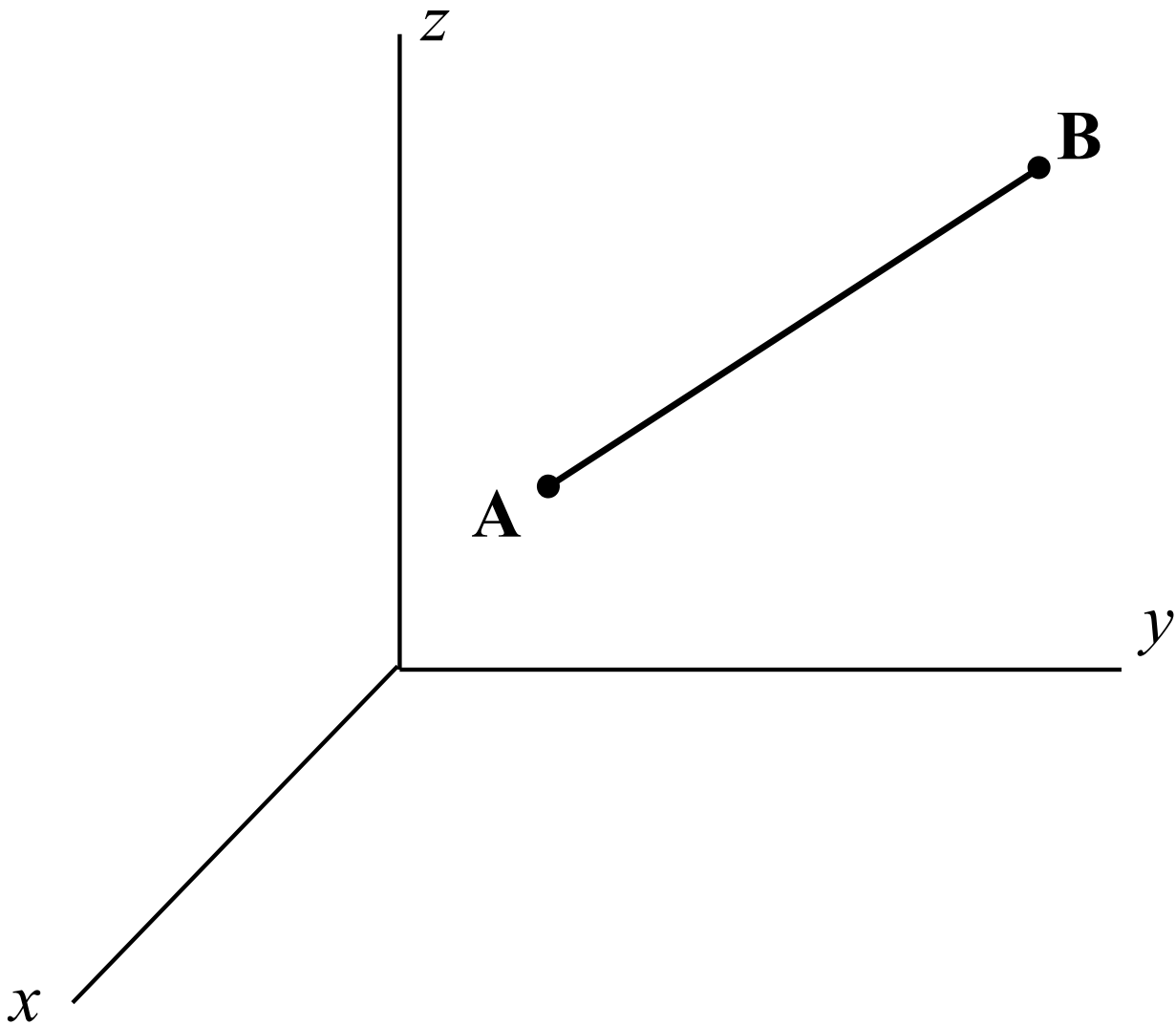

Unit vector along  $AB$  is  $\hat{\mathbf{\rho}}_{AB} = \frac{\mathbf{\rho}_{AB}}{|\mathbf{\rho}_{AB}|}$

Any vector passing through two points can be represented likewise



## Scalar (Dot) Product of Two Vectors

$$\mathbf{A} \cdot \mathbf{B} = A B \cos \alpha$$

- Dot product may involve vectors of different dimensional representation

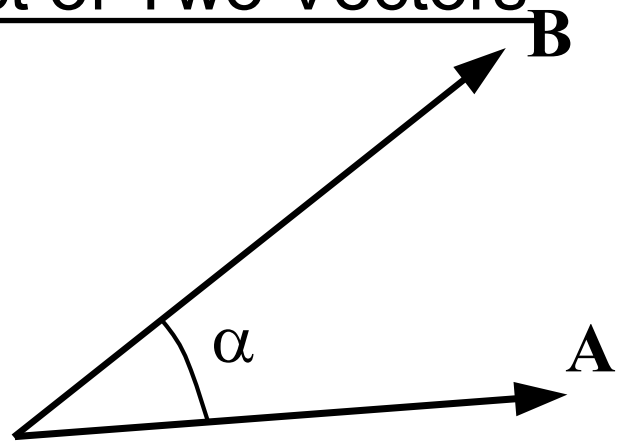

- May be positive or negative
- Physically  $\mathbf{A}$  is projected onto the direction of  $\mathbf{B}$  (to get  $A \cos \alpha$ ) and then multiplied by  $B$
- Work done by a force  $\mathbf{F}$  on a particle moving along a path  $s$  is given by

$$W = \int \mathbf{F} \cdot d\mathbf{s}$$

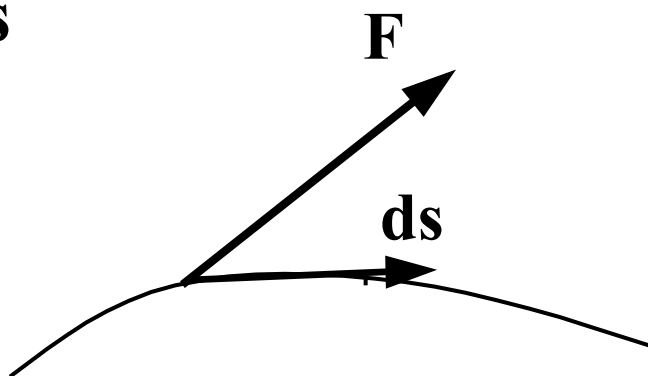

$$m\mathbf{A} \cdot n\mathbf{B} = mn (\mathbf{A} \cdot \mathbf{B})$$

$$\mathbf{A} \cdot \mathbf{B} = \mathbf{B} \cdot \mathbf{A}$$

$$\mathbf{A} \cdot (\mathbf{B} + \mathbf{C}) = \mathbf{A} \cdot \mathbf{B} + \mathbf{A} \cdot \mathbf{C}$$

If  $\mathbf{A} = A_x \mathbf{i} + A_y \mathbf{j} + A_z \mathbf{k}$

And  $\mathbf{B} = B_x \mathbf{i} + B_y \mathbf{j} + B_z \mathbf{k}$

$$\mathbf{A} \cdot \mathbf{B} = A_x B_x + A_y B_y + A_z B_z$$

$$\mathbf{A} = \begin{Bmatrix} A_x \\ A_y \\ A_z \end{Bmatrix} \quad \mathbf{B} = \begin{Bmatrix} B_x \\ B_y \\ B_z \end{Bmatrix}$$

$$\mathbf{A} + \mathbf{B} = \begin{Bmatrix} A_x + B_x \\ A_y + B_y \\ A_z + B_z \end{Bmatrix}$$

$$\mathbf{A} \cdot \mathbf{B} = \mathbf{A}^T \mathbf{B} = \mathbf{B}^T \mathbf{A}$$

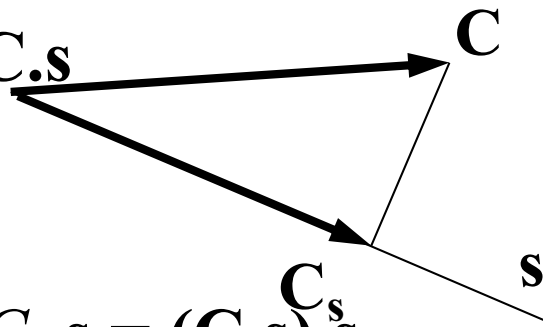

The scalar component of a vector  $\mathbf{C}$  along a given direction  $\mathbf{s}$  is

$$C_s = \mathbf{C} \cdot \mathbf{s}$$

Hence,

$$\mathbf{C}_s = C_s \mathbf{s} = (\mathbf{C} \cdot \mathbf{s}) \mathbf{s}$$

Let  $\rho$  be a unit vector along a direction:

Then,

$$\rho \cdot \mathbf{i} = |\rho| |\mathbf{i}| \cos(\rho, \mathbf{x}) = l$$

Or

$$\rho = l \mathbf{i} + m \mathbf{j} + n \mathbf{k}$$

$l, m, n$  are the direction cosines

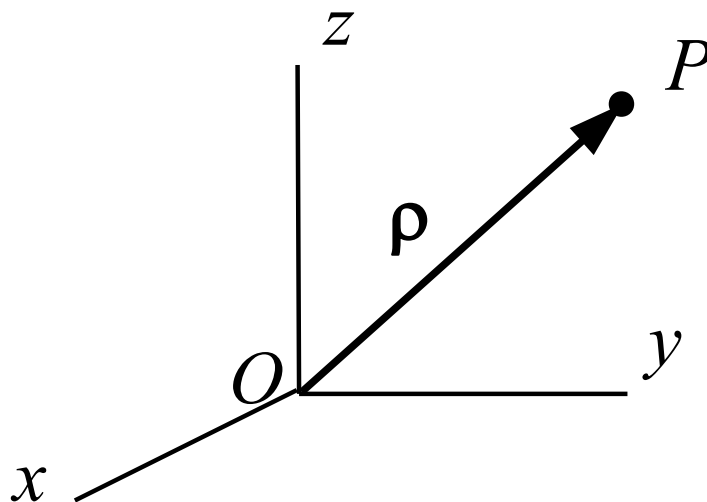

# Cross Product of Two Vectors

$$\mathbf{C} = \mathbf{A} \times \mathbf{B}$$

$$|\mathbf{C}| = |\mathbf{A}| |\mathbf{B}| \sin \alpha$$

$\mathbf{C}$  is directed normal  
to the plane

containing  $\mathbf{A}$  and  $\mathbf{B}$

and the sense is

governed by the right hand screw rule

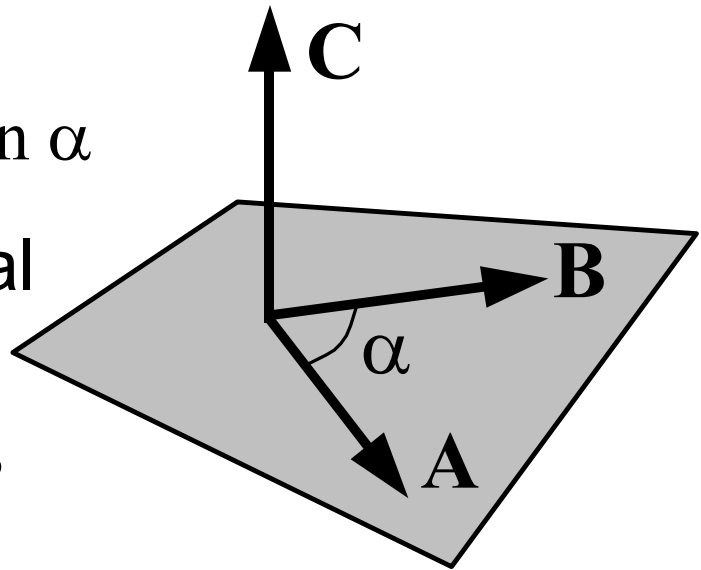

$$\mathbf{A} \times \mathbf{B} = -(\mathbf{B} \times \mathbf{A})$$

(violates commutative law)

$$\mathbf{C} \times (\mathbf{A} + \mathbf{B}) = \mathbf{C} \times \mathbf{A} + \mathbf{C} \times \mathbf{B}$$

(distributive law)

$\mathbf{i} \times \mathbf{j} = \mathbf{k}$  etc.;

$$\mathbf{A} \times \mathbf{B} = \begin{vmatrix} \mathbf{i} & \mathbf{j} & \mathbf{k} \\ A_x & A_y & A_z \\ B_x & B_y & B_z \end{vmatrix}$$



Given the coordinates of the vertices of A, B, C of a triangle, determine a unit normal vector to the plane of the triangle.

Determine  $\rho_{AB}$  and  $\rho_{AC}$ . Then,

$$\mathbf{n} = \frac{\rho_{AB} \times \rho_{AC}}{|\rho_{AB} \times \rho_{AC}|}$$

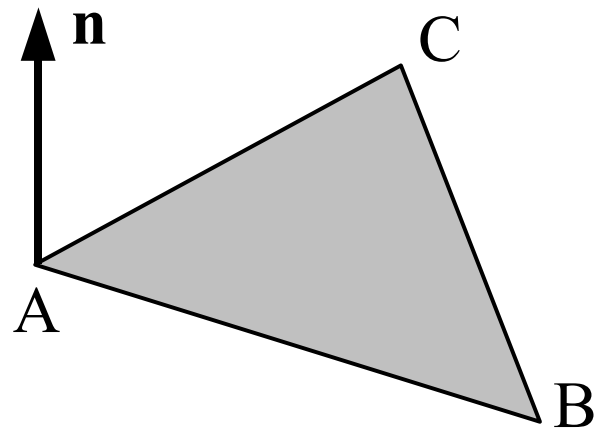

**Scalar Triple Product** is defined as

$$(\mathbf{A} \times \mathbf{B}) \cdot \mathbf{C}$$

and represents the volume of a parallelepiped

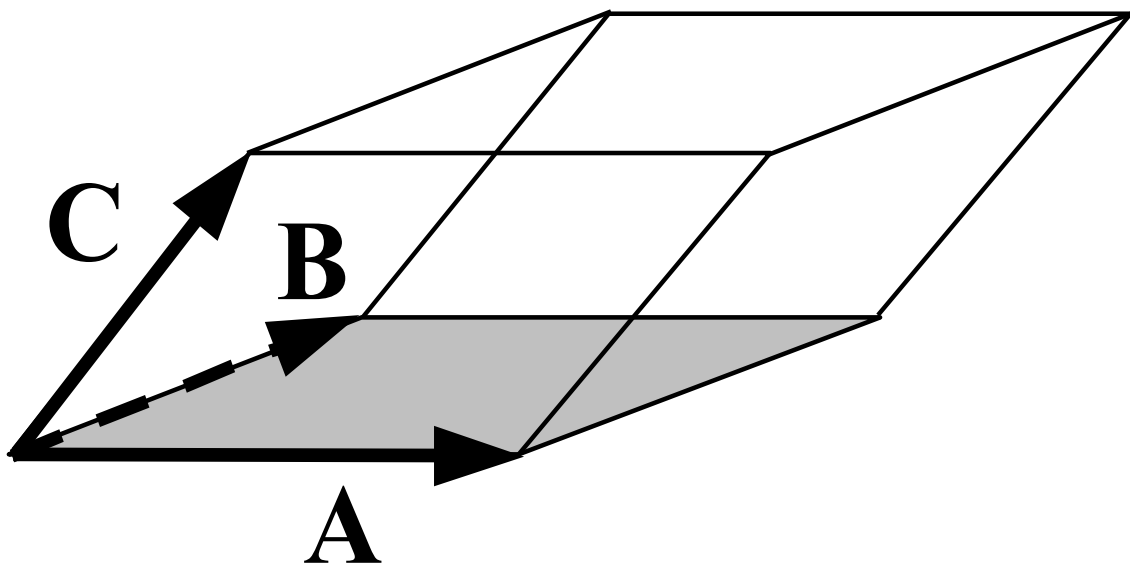



$$\mathbf{A} \times \mathbf{B} \cdot \mathbf{C} = \begin{vmatrix} A_x & A_y & A_z \\ B_x & B_y & B_z \\ C_x & C_y & C_z \end{vmatrix}$$

$$(\mathbf{A} \times \mathbf{B}) \cdot \mathbf{C} = -(\mathbf{A} \times \mathbf{C}) \cdot \mathbf{B} = -(\mathbf{C} \times \mathbf{B}) \cdot \mathbf{A}$$

## Vector Triple Product

$$\mathbf{A} \times (\mathbf{B} \times \mathbf{C}) = \mathbf{B} (\mathbf{A} \cdot \mathbf{C}) - \mathbf{C} (\mathbf{A} \cdot \mathbf{B})$$

Exercise: Given point A (2, 2, 0) m, B (0, 3, 0) m and C (3, -2, 1). Represent a force of 1 kN which passes through A and B. Also represent the displacement vector  $\rho_{OC}$  connecting the origin O and C. What is the angle between the vectors?



# Important Vector Quantities

Position Vector: is the directed line segment from origin  $O$  of a coordinate system to the point  $P$  in space.

$$\mathbf{r} = x \mathbf{i} + y \mathbf{j} + z \mathbf{k}$$

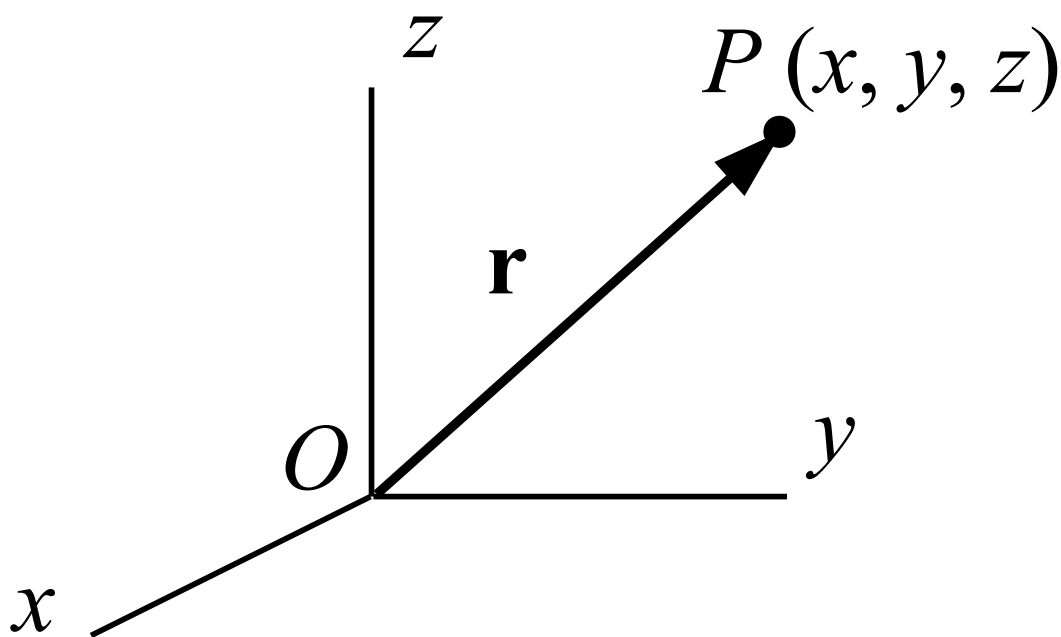

Moment of a Force About a Point: is a vector  $\mathbf{M}$  with magnitude equal to product of force magnitude and perpendicular distance  $d$  from  $O$  to line of action of the force  $\mathbf{F}$ , and sense determined from right-hand screw rule.

$$\mathbf{M} = \mathbf{r} \times \mathbf{F}$$

$\mathbf{r}$  is the position vector of any point  $P$  on the line of action of  $\mathbf{F}$  with respect to  $O$ .

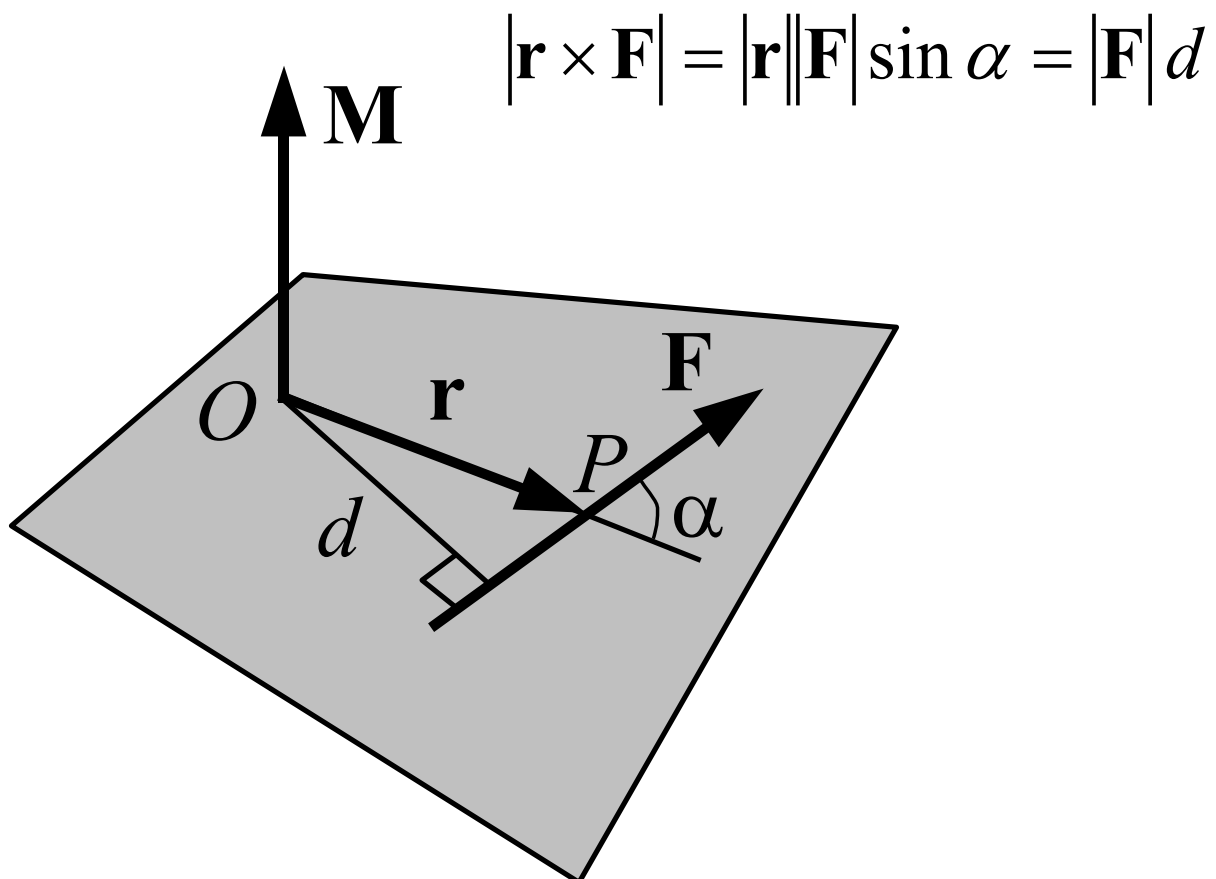

Consider a system of forces

$$\mathbf{F}_i, i = 1 \text{ to } n$$

Moment of all the forces about the origin  $O$  is:

$$\begin{aligned}\mathbf{M} &= \mathbf{M}_1 + \mathbf{M}_2 + \dots + \mathbf{M}_n \\ &= \mathbf{r} \times \mathbf{F}_1 + \mathbf{r} \times \mathbf{F}_2 + \dots + \mathbf{r} \times \mathbf{F}_n \\ &= \mathbf{r} \times (\mathbf{F}_1 + \mathbf{F}_2 + \dots + \mathbf{F}_n)\end{aligned}$$

This is called the Varignon's Theorem

*“The sum of moments about a point of a system of concurrent forces equals the moment about the same point of the sum of the forces”*

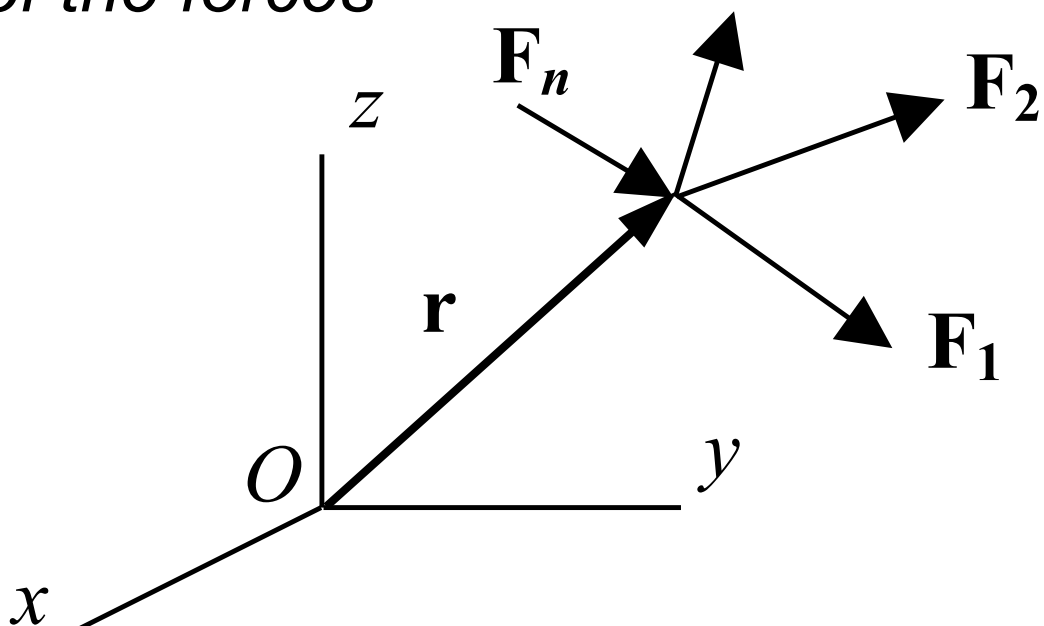

## Moment of a Force About an Axis

Consider the disc mounted on the shaft.

A force  $\mathbf{F}$  inclined to the plane of the disc acts on the disc.

Decompose  $\mathbf{F}$  into  $\mathbf{F}_B$  (normal to plane of disc) and  $\mathbf{F}_A$  (tangential to plane).

The rotational moment =  $F_A \times d$ , and is the moment of  $\mathbf{F}$  about the axis  $BB$ .

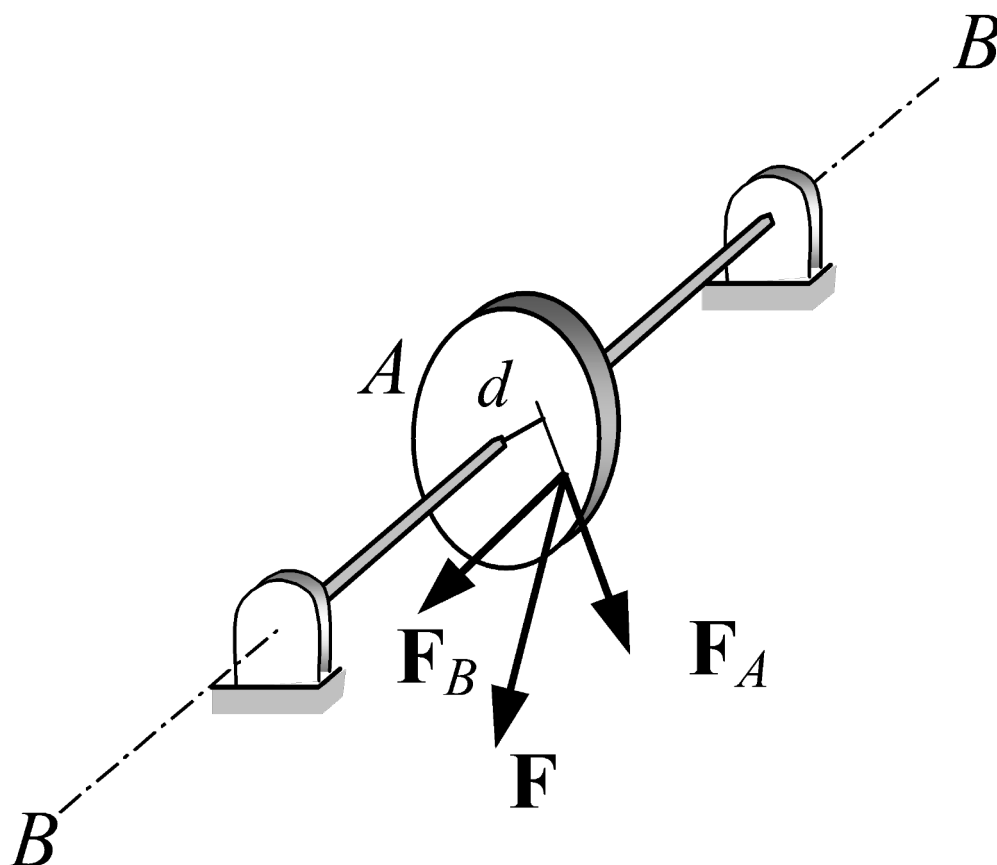

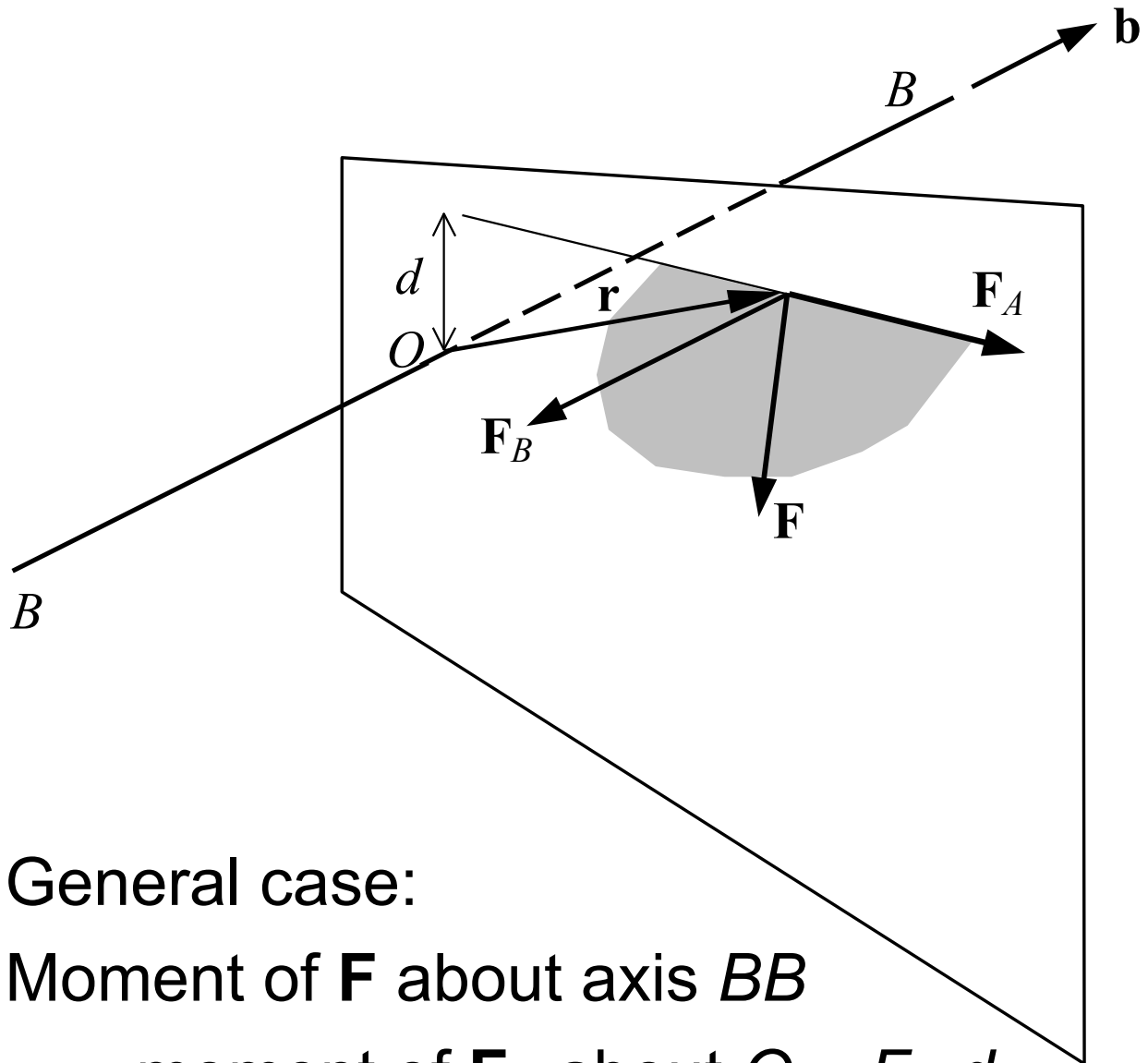

General case:

Moment of  $\mathbf{F}$  about axis  $BB$

= moment of  $\mathbf{F}_A$  about  $O = F_A d$

It is a scalar. It is given by

$$\mathbf{M}_b = (\mathbf{r} \times \mathbf{F}) \cdot \mathbf{b}$$

where  $\mathbf{r}$  is the position vector of any point on the line of action of  $\mathbf{F}$  w.r.t any point  $O$  on the axis  $BB$

$\mathbf{b}$  is the unit vector along  $BB$ .



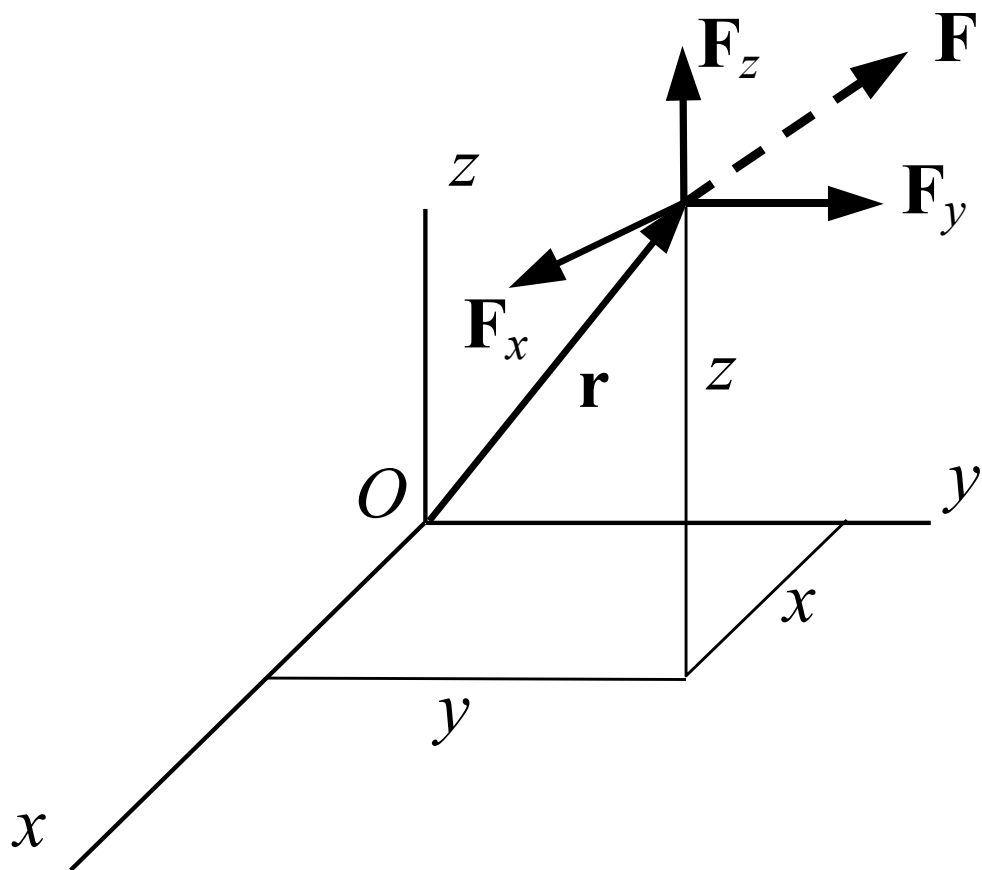

Moment of  $\mathbf{F}$  about  $O$ :

$$\mathbf{M} = \mathbf{r} \times \mathbf{F} = \begin{vmatrix} \mathbf{i} & \mathbf{j} & \mathbf{k} \\ x & y & z \\ F_x & F_y & F_z \end{vmatrix}$$

$$= (yF_z - zF_y)\mathbf{i} + (zF_x - xF_z)\mathbf{j} + (xF_y - yF_x)\mathbf{k}$$

$$= M_x\mathbf{i} + M_y\mathbf{j} + M_z\mathbf{k}$$

where  $M_x$  is the moment of  $\mathbf{F}$  about  $x$ -axis etc.



## Example

Find moment of  $\mathbf{F}$  about points A and B, and about the line AB.

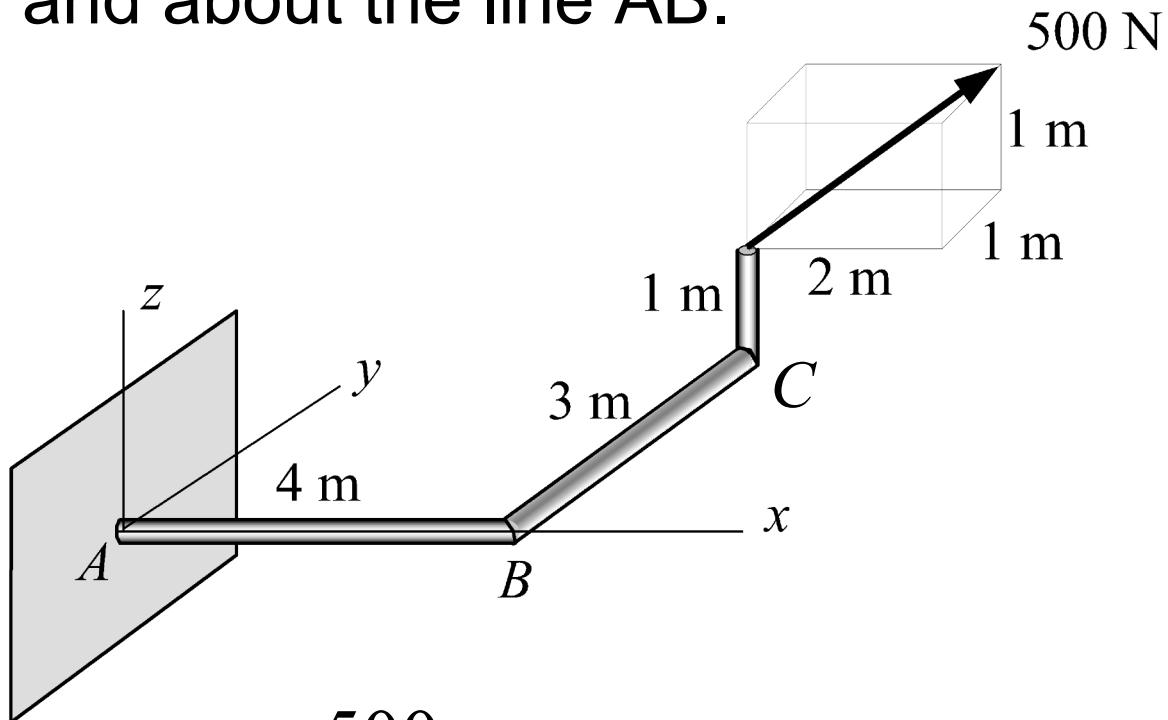

$$\mathbf{F} = \frac{500}{\sqrt{(2^2 + 1^2 + 1^2)}} (2\mathbf{i} + 1\mathbf{j} + 1\mathbf{k}) \text{ N}$$

$$\mathbf{r}_{AC} = (4\mathbf{i} + 3\mathbf{j} + 1\mathbf{k}) \text{ m}$$

$$\mathbf{M}_A = \mathbf{r} \times \mathbf{F} = \frac{500}{\sqrt{6}} \begin{vmatrix} \mathbf{i} & \mathbf{j} & \mathbf{k} \\ 4 & 3 & 1 \\ 2 & 1 & 1 \end{vmatrix} \text{ Nm}$$

$$M_{AB} = \mathbf{M}_A \bullet \mathbf{i} \text{ Nm}$$





## The Couple and the Couple Moment

Any two equal parallel forces with opposite senses constitute a couple

On a rigid body, couple has a “turning” action only; and no “pushing” or “pulling” actions

The turning action is quantitatively given by the “moment of the couple”

$$\mathbf{M} = \mathbf{r}_1 \times \mathbf{F} - \mathbf{r}_2 \times \mathbf{F} = (\mathbf{r}_1 - \mathbf{r}_2) \times \mathbf{F} = \mathbf{e} \times \mathbf{F}$$

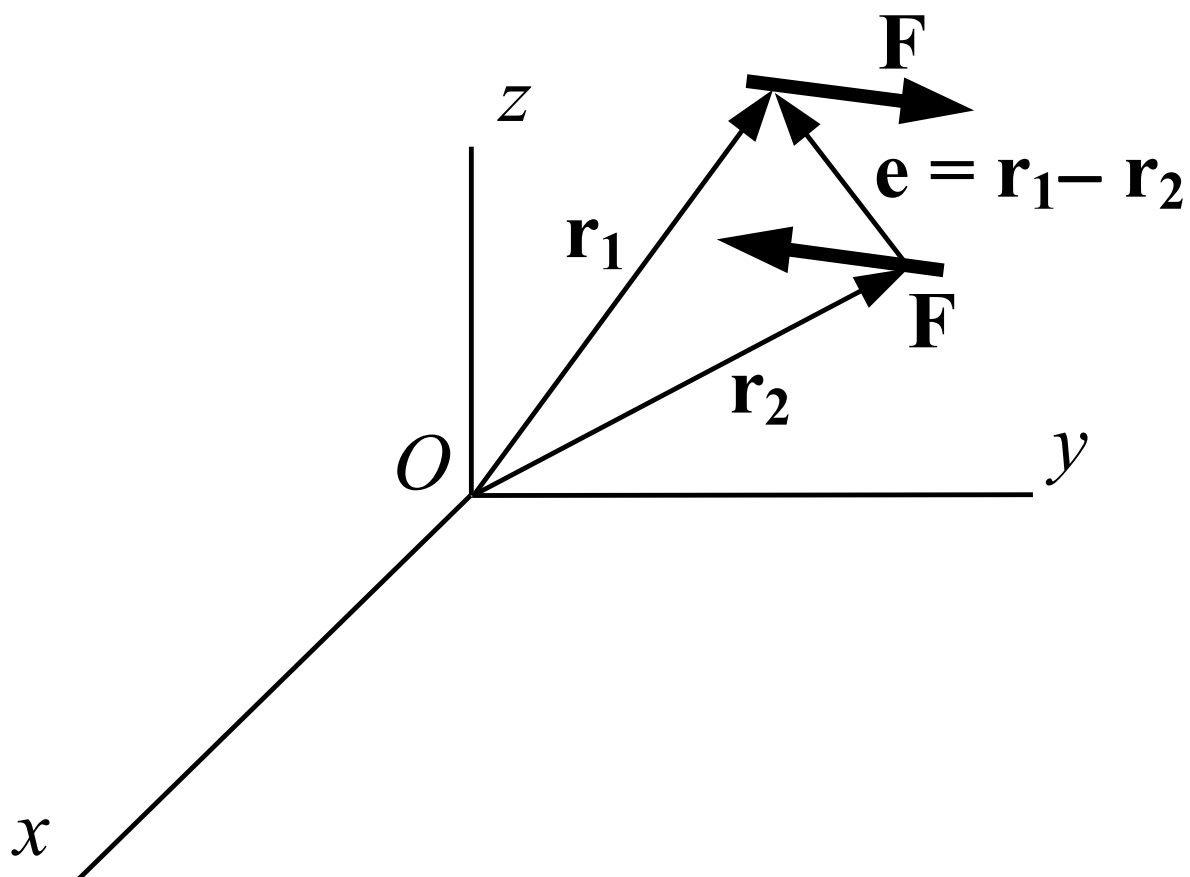

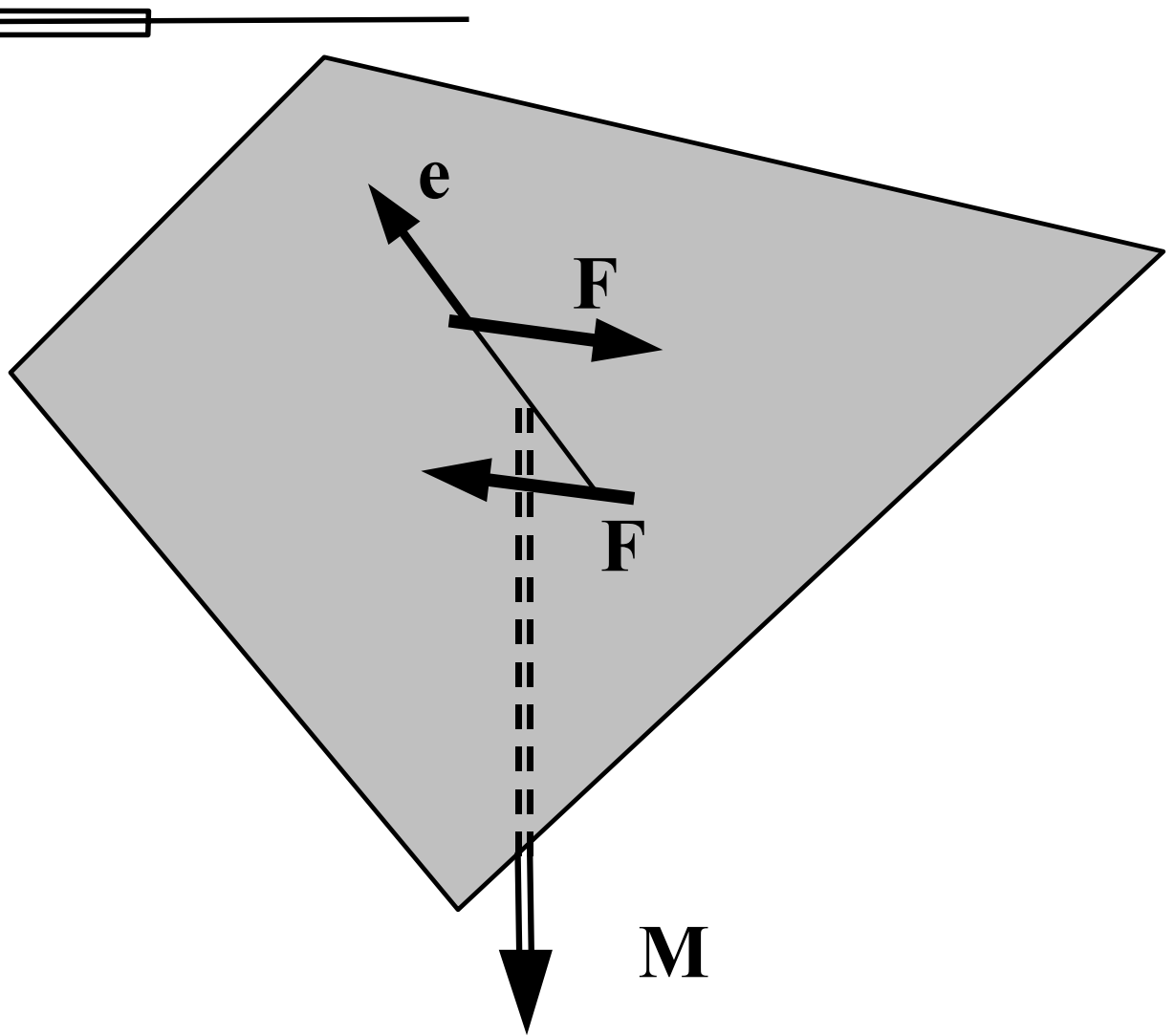

$$|\mathbf{M}| = |\mathbf{e}||\mathbf{F}|\sin \alpha = F d$$

$\mathbf{M}$  is oriented normal to the plane of the couple

The moment of a couple is a vector with magnitude =  $F.d$ , directed normal to the plane of the couple; the sense is given by the right hand screw rule



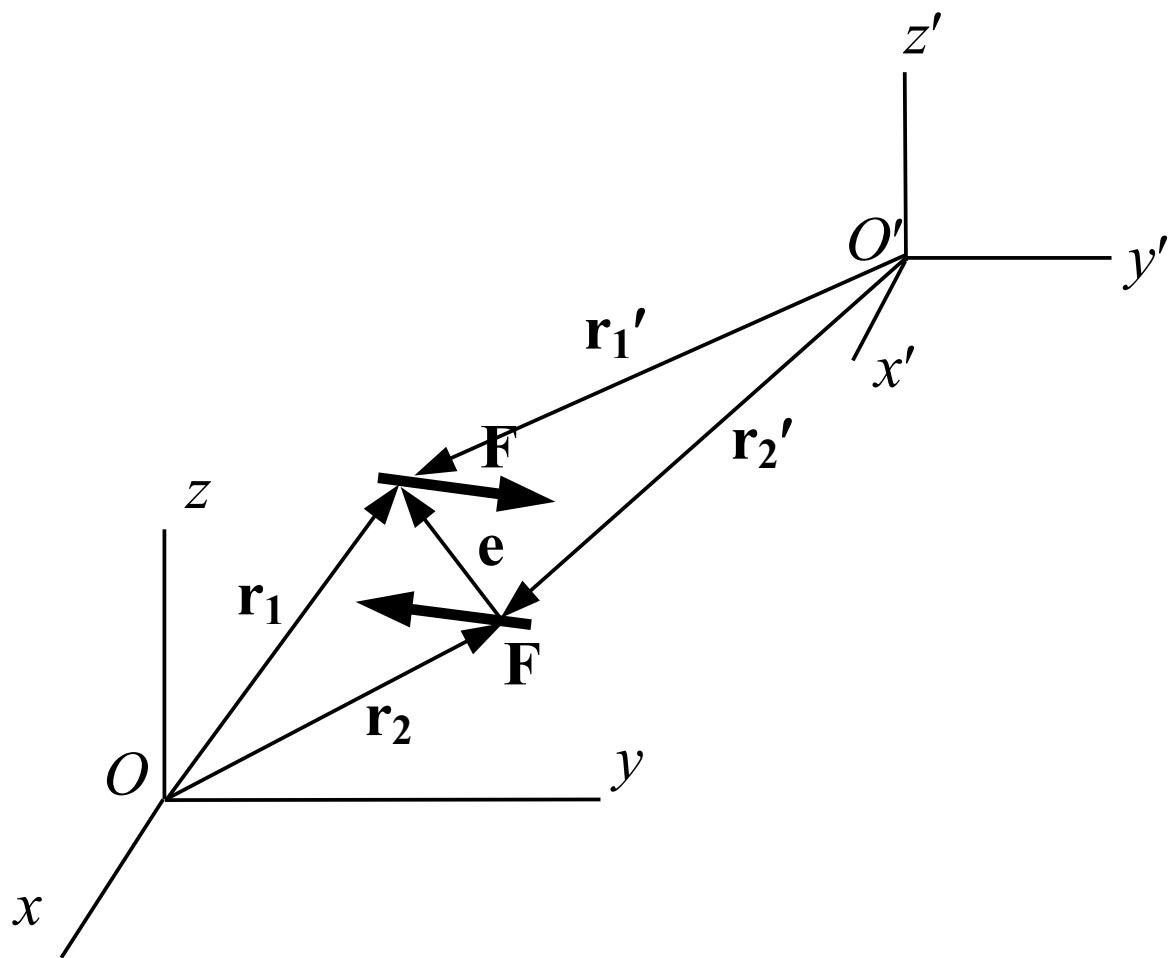

The couple moment is a free vector

Irrespective of the location of point  $O$ , moment of the couple remains the same and is given by  $\mathbf{M} = \mathbf{e} \times \mathbf{F}$

The couple has the same moment about any point in space—hence, it is a free vector.



We could change the distance between the two forces, and simultaneously change the force magnitude to retain same moment.

A couple can be represented by

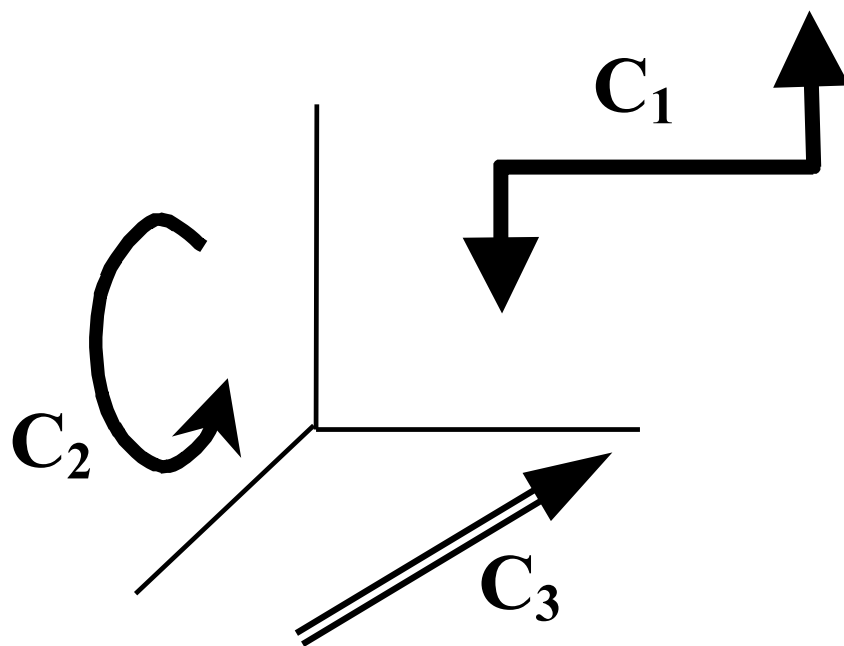

# Addition and Subtraction of Couples

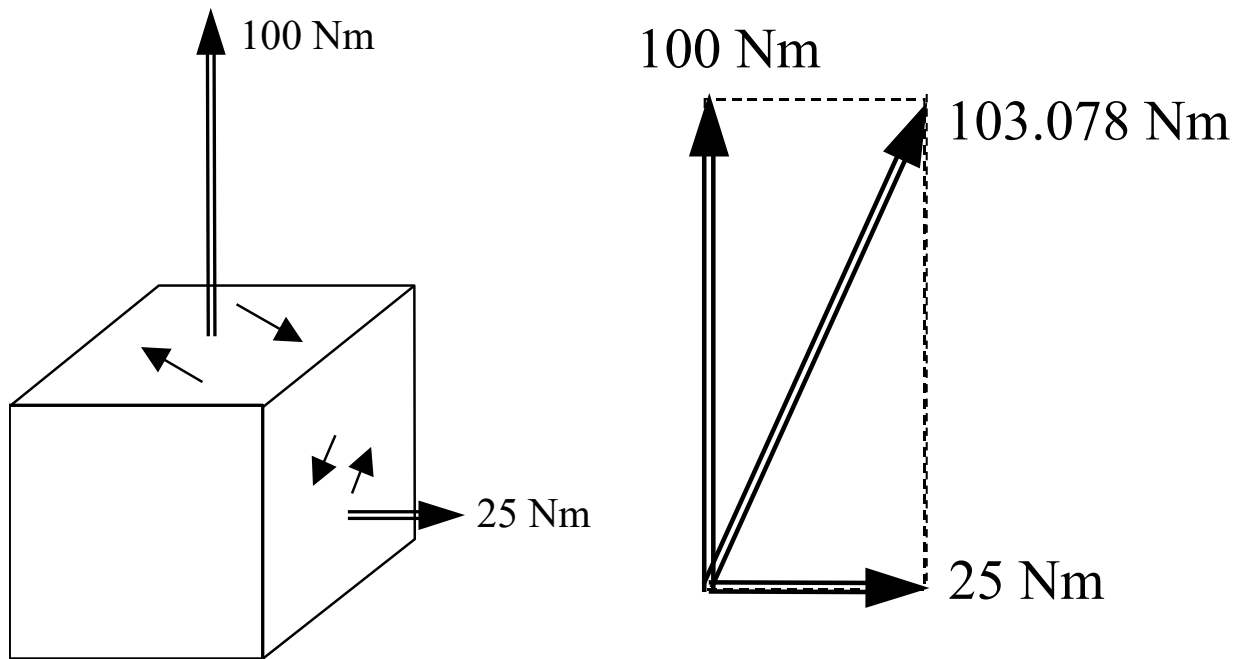

## Moment of a Couple About a Line

Moment of **C** about any point *P* on *AA* is **C** itself; hence, moment about *AA* is:

$$M_{AA} = \mathbf{C} \cdot \mathbf{n}$$

